



model 1210SF

Wall-Mount Filtered ADA Bottle Filler

FEATURES & BENEFITS

BOTTLE FILLER

Quick-fill sensor-operated bottle-filler provides accessibility to all users, has LED lighting to illuminate the fill area, and an integral basin that drains directly to the waste.

TOUCHFREE

Hygienic hands-free activation and sensor operation. Touchless bottle filling and rinsing application.

AUTO-PURGE

Bottle filler automatically purges the water line after 24 hours of non-use to prevent the development and growth of Legionella and other harmful bacteria.

SEPARATE FILL AREA

Raised platform for easy bottle resting and filling. The bottle-filling area is separate from the bottle pouring area to provide distinct clean and dirty areas.

FRESH FILTERED WATER

Always fresh, filtered water - 3000-gallon (11,356 L) capacity. Electronic Lifecycle Control filter cartridge will shut off water flow when capacity is reached. To ensure fresh, filtered water, flow will only start again when filter is changed. LED readout on bottle filler will notify user when capacity of filter is less than 10% remaining or expired.

TANKLESS EVAPORATOR

Energy-efficient thermal mass tankless evaporator coil flushes 100% of its water content with every use, eliminating stagnant water in tank reservoirs found in other products.

SMART ENERGY SAVINGS MODE

Energy saving feature allows unit to power off the refrigeration system after two hours of non-use. Unit will automatically start back up next time it is used.

MODERN INNOVATIVE DESIGN

Modern, innovative design with stainless-steel finish gives a sleek look and feel to high-end architectural spaces and lobbies. Unit projects off wall less than 8" for mounting in tight locations where a space is a premium.

ADA COMPLIANT

On-wall ADA-compliant reach and toe clearance when installed at proper ADA mounting heights. See ADA for full details.

UNIVERSAL MOUNTING

Specially designed internal configuration allows for mounting over existing competitors' rough-ins.

ELECTRONIC DISPLAY

Intuitive LED electronic display informs users when the bottle filler is activated, when the water is being filtered and how many plastic bottles have been saved.

PROGRAMMABLE SETTINGS

Programmable off mode during planned facility shutdowns, multiple digital readout settings for bright or dim display, adjustable sensor range, and review settings and error codes.



SPECIFICATIONS

Model 1210SF indoor wall-mount ADA stainless steel bottle filling station shall include an ASHRAE compliant, hermetically-sealed R-134a refrigeration system with adjustable thermostat. Unit features a unique, modern design with stainless steel outer shell. Energy savings feature powers down refrigeration system after two hours of non-use, and will automatically start again when used. The unit can also be programmed to shut down during planned facility closures, weekends, etc. Digital LED interface keeps user apprised of programming and error codes. The 3000-gallon (11,356 L) filter with Electronic Lifecycle Control turns water off when capacity is reached. Flow will begin again when new filter is installed. Bottle filler basin drains directly to the units waste. The system enacts a bottle filler auto purge every 24 hours to prevent buildup of Legionella and other harmful bacteria, includes an instantaneous tankless water cooler for consistent cool water, and LED illuminated bottle fill area. 115 Volts, 60Hz, rated watts: 350, full load amps: 5. Dimensions: 7-7/8 x 15-11/16 x 41-7/8 (L x W x H)

APPLICATIONS

Great for schools, office buildings, shopping malls, and other indoor environments where there is a demand for a chilled water source. CSA certified to comply with NSF/ANSI 42, 53, 61 and 372, ASME A112.18.1/CSA B125.1, ASME112.19.3/CSA B45.4, UL 399 and CSA C22.2 No. 120. ADA compliant to ICC A117.1, CSA B651, DOJ's 2010 ADA Standards for Accessible Design when properly installed. ASHRAE 18 compliant chilling capacity. FCC ID: 2AUAN-1200SM and IC: 25359-1200SM.

Electric water coolers are not recommended or designed for outdoor applications or enclosed pool areas (chlorine), and failure to heed these conditions may void warranty. 5-Year Limited Warranty on the refrigeration system of the unit. Electrical components and water system are warranted for 12 months from date of installation. Warranty pertains to drinking water applications only.



NOTES:

1. HOLD PLUMBING & ELECTRICAL DIMENSIONS $\pm 1/4"$ (6.4mm). HOLD MOUNTING DIMENSIONS $\pm 1/8"$ [± 3.2 MM].
2. ADHERING TO PROVIDED INSTALLATION HEIGHT DIMENSIONS WILL ALLOW THE BOTTLE FILLER TO BE INSTALLED AT ADULT ADA HEIGHT. IN MOST CASES, DIMENSIONS MARKED * CAN BE INCREASED BY UP TO 4" IN EQUIVALENT AMOUNTS. WHEN INSTALLING THIS UNIT, LOCAL, STATE, OR FEDERAL CODES SHOULD BE ADHERED TO.

**TYPICAL INSTALLATION
(SOME COMPONENTS HIDDEN FOR CLARITY)**

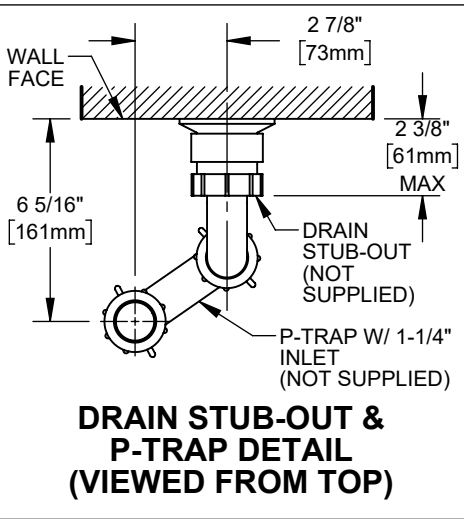

120VAC GFCI-PROTECTED ELECTRICAL RECEPTACLE, MIN. 15A SERVICE (USE STANDARD SIZE 4.5X2.75" WALLPLATE). DEDICATED CIRCUIT RECOMMENDED

P-TRAP W/1-1/4" INLET (NOT SUPPLIED)

SUPPLY VALVE (NOT SUPPLIED; REC. 90° VALVE W/ 1/2" IPS SUPPLY & 3/8" COMPRESSION OR QUICK CONNECT TUBING OUTLET)

MOUNTING BRACKET

* 43 3/4" [1111mm] SENSOR

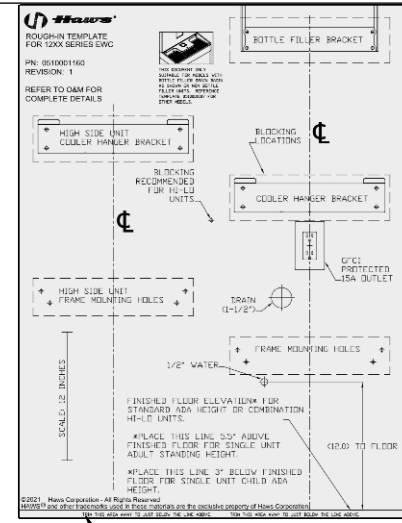
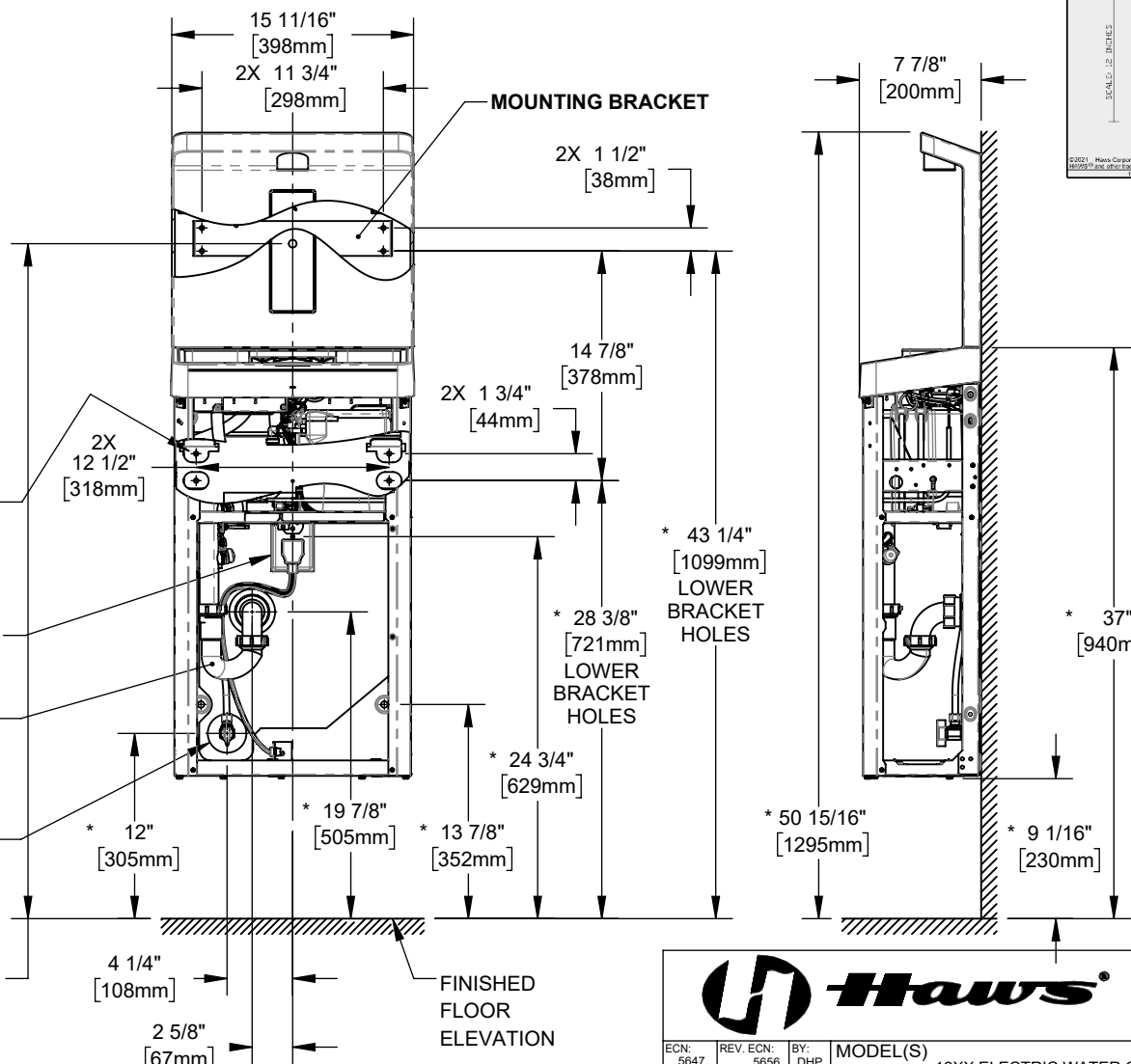

FULL SCALE
ROUGH-IN TEMPLATE
PN 0510001160
AVAILABLE UPON REQUEST.

Haws

1455 KLEPPE LANE
SPARKS, NEVADA 89431
(775) 359-4712 FAX (775) 359-7424
E-MAIL: HAWS@HAWSO.COM
WEBSITE: WWW.HAWSO.COM

| | | | | |
|--------------|----------------|-----------|-----------------------------|--------------|
| ECN: 5647 | REV. ECN: 5656 | BY: DHP | MODEL(S) | PART NUMBER |
| DRAWN: JL | DATE: 07/25/18 | CHKD: DHP | 12XX ELECTRIC WATER COOLERS | 0510001159.D |
| APPROVED: JL | DATE: 02/11/21 | | SCALE: 1:12 | REVISION |
| | | | DRAWING TYPE: INSTALLATION | 1 |
| | | | SIZE: A | SHEET 1 OF 5 |

BOTTLE FILLER INSTALLATION DETAILS

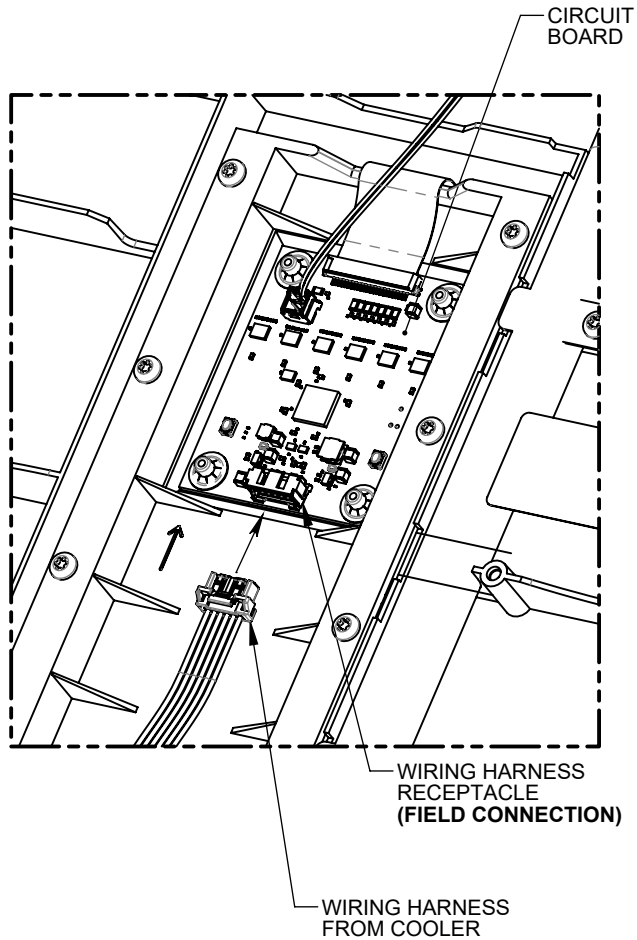

**WIRING HARNESS CONNECTION
(REAR OF BOTTLE FILLER)**

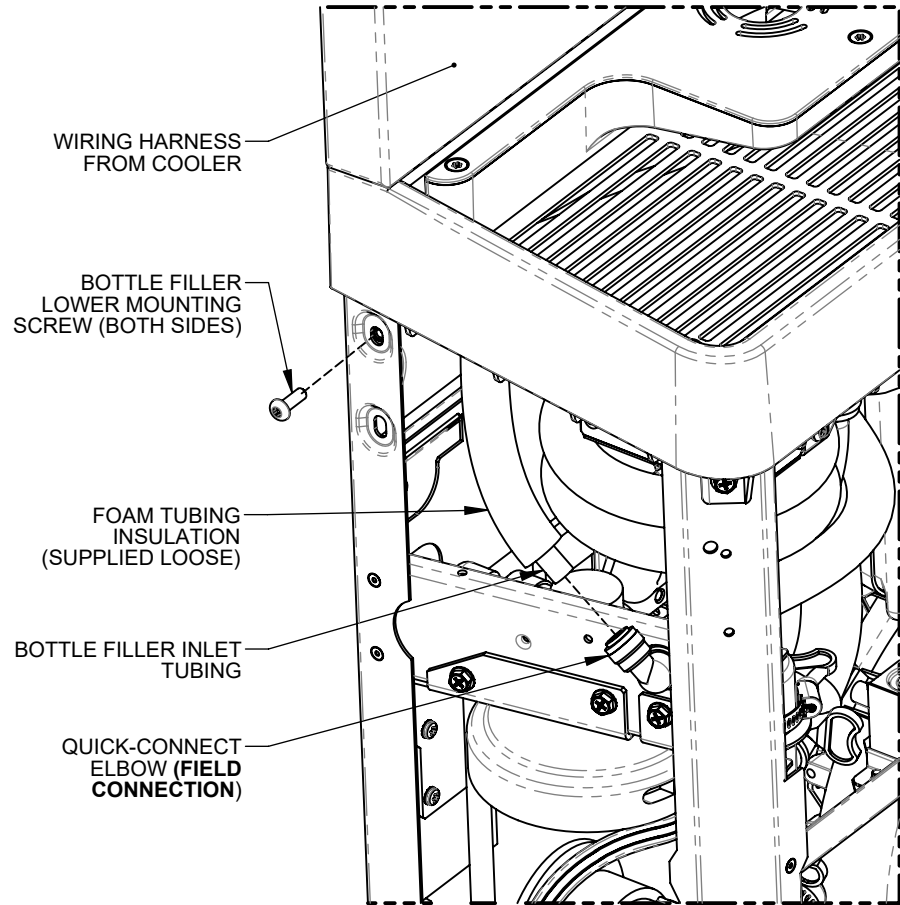

**BOTTLE FILLER MOUNTING &
TUBING CONNECTION**



1455 KLEPPE LANE
SPARKS, NEVADA 89431
(775) 359-4712 FAX (775) 359-7424
E-MAIL: HAWS@HAWS.CO.COM
WEBSITE: WWW.HAWS.CO.COM

| | | | | |
|-----------------|-------------------|--------------|--|-----------------------------|
| ECN: 5647 | REV. ECN: 5656 | BY: DHP | MODEL(S) 12XX ELECTRIC WATER COOLERS | PART NUMBER 0510001159.D |
| DRAWN: JL | DATE: 07/25/18 | CHKD: DHP | | REVISION 1 |
| APPROVED: JL | DATE: 02/11/21 | | SCALE: 1:12 DRAWING TYPE: INSTALLATION | SIZE: A SHEET 2 OF 5 |

RETROFIT INSTALLATION DETAILS

3 RETROFIT TABLE

| BRACKET HEIGHT | | |
|----------------|---------------|-----------|
| ADULT ADA MAX | ADULT ADA MIN | CHILD ADA |
| 32 3/8" | 28 3/8" | 25 3/8" |

| MANUFACTURER | MODEL |
|---------------------|--|
| HAWS | ALL MODELS STARTING WITH HWUACP |
| ELKAY/HALSEY TAYLOR | - ALL MODELS STARTING WITH EB, EI, EMA, EN, EZ, HAC HVR, LI, LMA, LZ, TB, & TI - SINGLE COOLER MODELS STARTING WITH VRC & LVR |
| OASIS | ALL VERSACOOLER II MODELS |
| SUNROC | ALL MODELS STARTING WITH ADA A171, A171.8, & A172.8UBL MODELS |
| MURDOCK | NOTE: THE WATER STOP VALVE MUST BE RELOCATED TO RETROFIT A FILTERED 12XX COOLER |

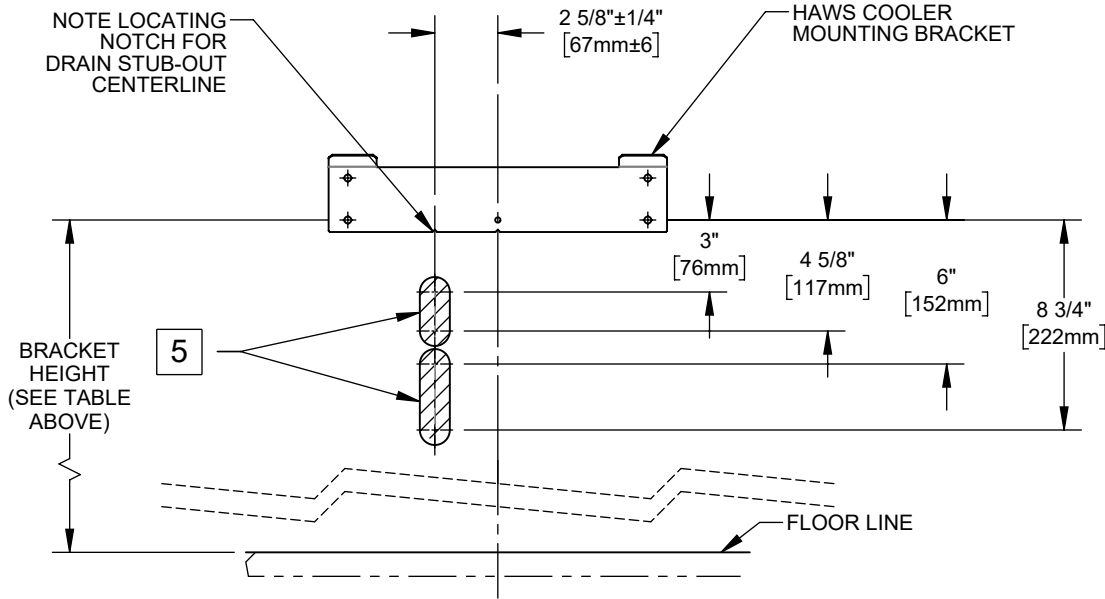

PERMISSIBLE LOCATIONS FOR DRAIN STUB-OUT

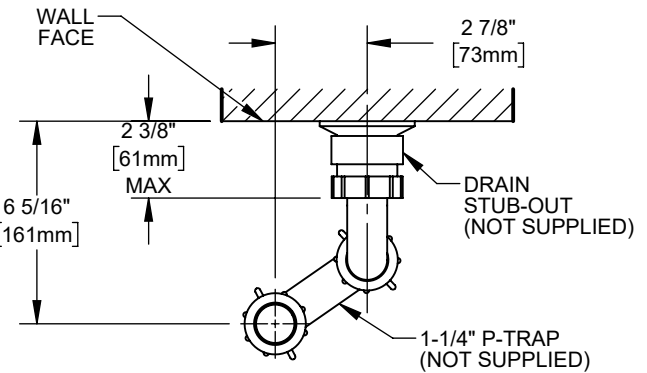

6 DRAIN STUB-OUT/P-TRAP DETAIL (VIEWED FROM TOP)

NOTES:

- THE 12XX COOLER SERIES IS ABLE TO RETROFIT IN PLACE OF A NUMBER OF COMPETITOR MODELS. SEE RETROFIT TABLE ABOVE FOR PARTIAL LIST OF COOLERS ABLE TO BE REPLACED BY THIS ONE. **THE FOLLOWING DISCLAIMERS APPLY:**
 - THE 12XX COOLER CENTERLINE MAY NOT MATCH THE OLD COOLER'S CENTERLINE, SINCE THE 12XX COOLER DRAIN MUST BE 2 5/8" OFF OF CENTER. THIS MAY AFFECT ADA COMPLIANCE.
 - THERE MUST BE WALL BLOCKING OR OTHER STRUCTURAL MATERIAL BEHIND HAWS MOUNTING HOLES.
 - VERIFY THAT DRAIN, ELECTRIC, & WATER SERVICES ARE LOCATED WITHIN BOUNDARIES SPECIFIED ON THIS SHEET AND THE NEXT. SOME RETROFITS MAY REQUIRE THE ELECTRIC OUTLET TO BE MOVED.
- THE P-TRAP IS NOT SUPPLIED. THE VERTICAL DIMENSIONS GIVEN ARE BASED UPON INSTALLATION USING OF A KEENEY 200W P-TRAP, AND SHOULD THEREFORE BE REGARDED AS REFERENCE-ONLY.
- THE CENTERLINE OF THE DRAIN STUB-OUT MUST BE BETWEEN 3" [76mm] & 4-5/8" [118mm] OR BETWEEN 6" [152mm] & 8-3/4" [229mm] BELOW THE LOWERMOST EWC MOUNTING BRACKET HOLES IN ORDER FOR THE P-TRAP TO AFFIX PROPERLY TO THE DRAIN TAILPIECE.
 - DEPENDING ON STUB-OUT HEIGHT, SOME TRIMMING OF THE TAILPIECE WILL BE REQUIRED.
- WHATEVER P-TRAP AND STUB-OUT PLUMBING ARE USED, CARE SHOULD BE TAKEN TO ENSURE THAT THE P-TRAP CAN SEAL TO THE STUB-OUT PROPERLY AND STILL ALIGN TO THE DRAIN TAILPIECE (LOCATED AT THE GIVEN DIMENSIONS).

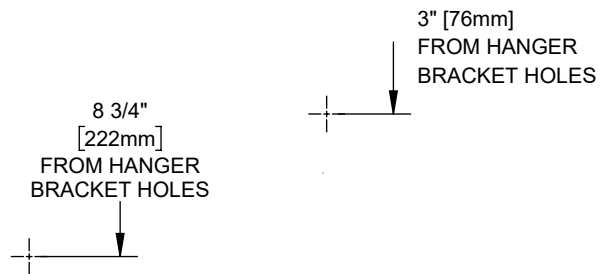

5 HIGHEST & LOWEST P-TRAP HEIGHTS



1455 KLEPPE LANE
SPARKS, NEVADA 89431
(775) 359-4712 FAX (775) 359-7424
E-MAIL: HAWS@HAWSCO.COM
WEBSITE: WWW.HAWSCO.COM

| | | | | |
|--------------|----------------|------------|-----------------------------|--------------|
| ECN: 5647 | REV. ECN: 5656 | BY: DHP | MODEL(S) | PART NUMBER |
| DRAWN: JL | DATE: 07/25/18 | CHKD: DHP | 12XX ELECTRIC WATER COOLERS | 0510001159.D |
| APPROVED: JL | DATE: 02/11/21 | SCALE: 1:8 | DRAWING TYPE: INSTALLATION | REVISION |
| | | | SIZE: A | 1 |
| | | | | SHEET 3 OF 5 |

RETROFIT INSTALLATION DETAILS

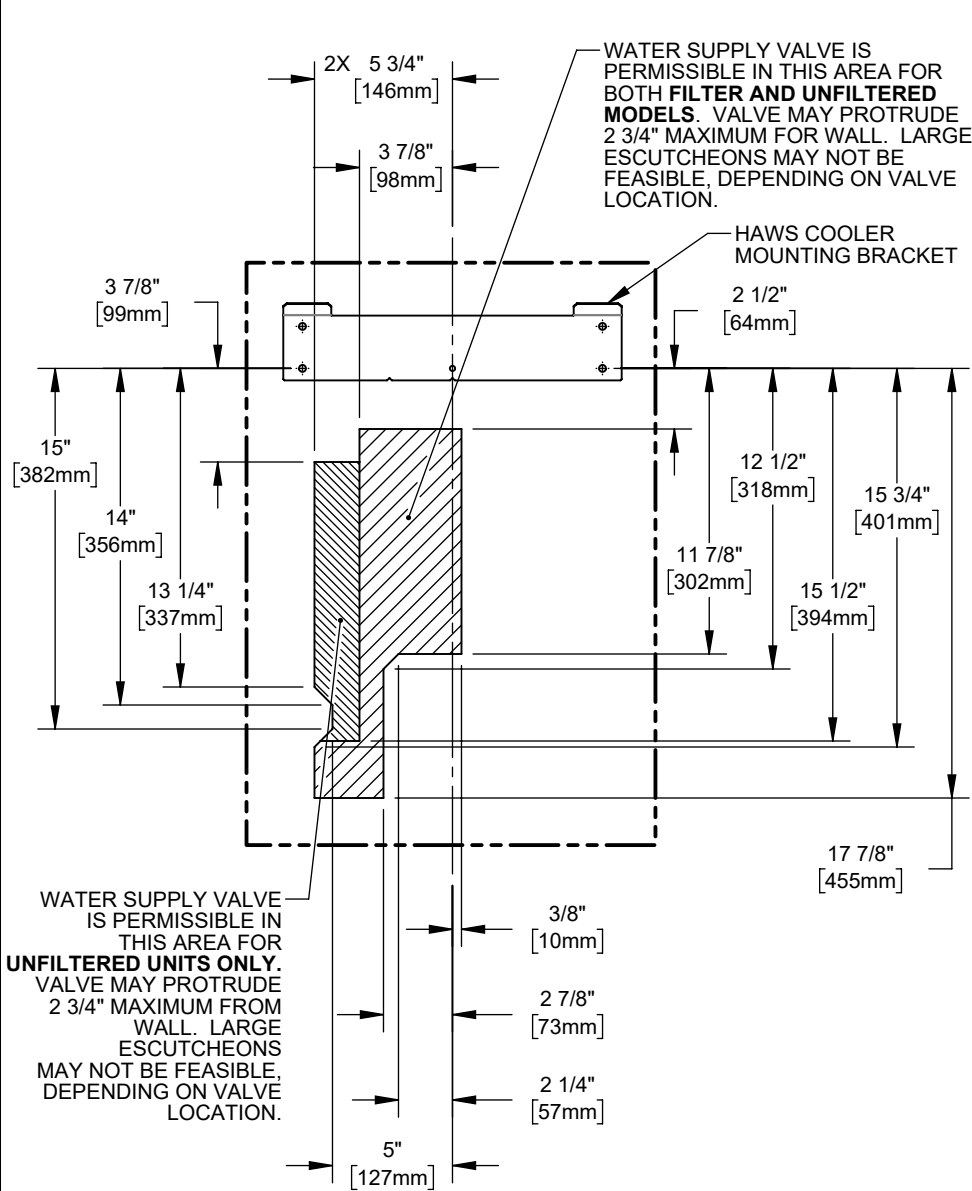

**PERMISSIBLE WATER
SUPPLY LOCATIONS**

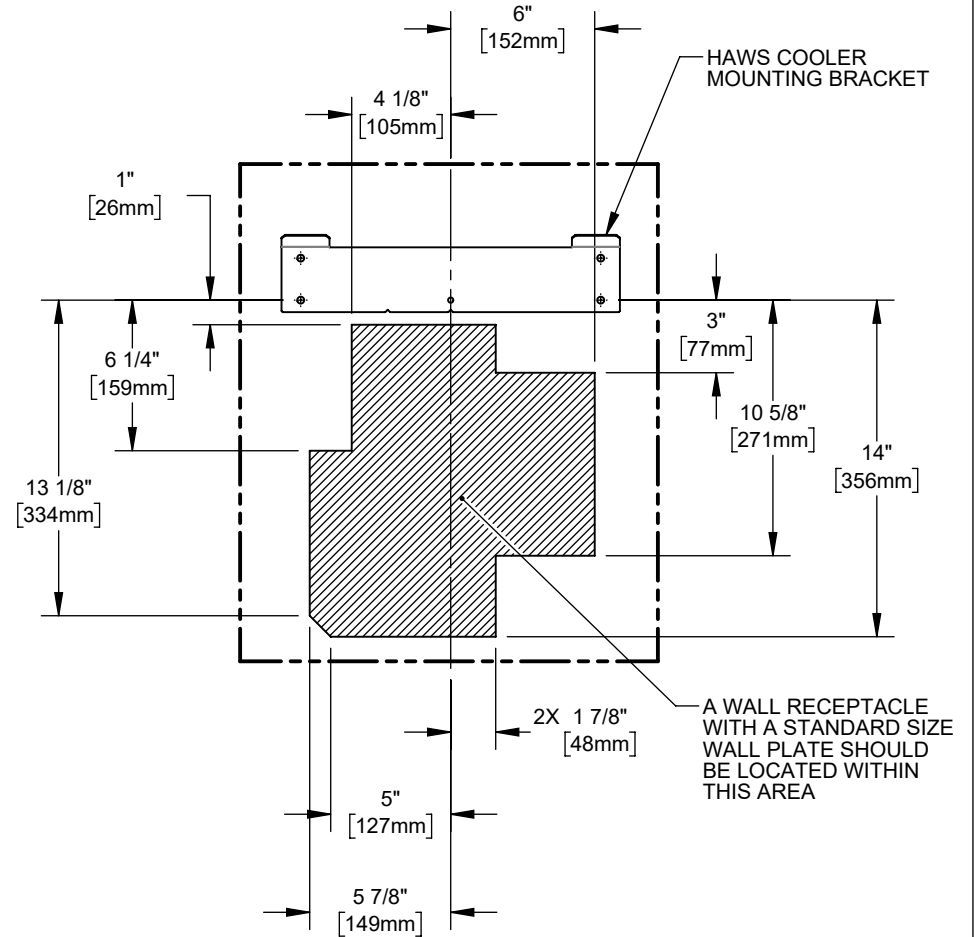

**PERMISSIBLE ELECTRICAL
RECEPTACLE LOCATIONS**

| | | | |
|--------------|----------------|---|---|
| Haws | | 1455 KLEPPE LANE SPARKS, NEVADA 89431 (775) 359-4712 FAX (775) 359-7424 E-MAIL: HAWS@HAWSCO.COM WEBSITE: WWW.HAWSCO.COM | |
| ECN: 5647 | REV. ECN: 5656 | BY: DHP | MODEL(S) 12XX ELECTRIC WATER COOLERS |
| DRAWN: JL | DATE: 07/25/18 | CHKD: DHP | PART NUMBER 0510001159.D |
| APPROVED: JL | DATE: 02/11/21 | SCALE: 1:8 | DRAWING TYPE: INSTALLATION |
| | | SIZE: A | REVISION 1 |
| | | SHEET 4 OF 5 | |

MAINTENANCE

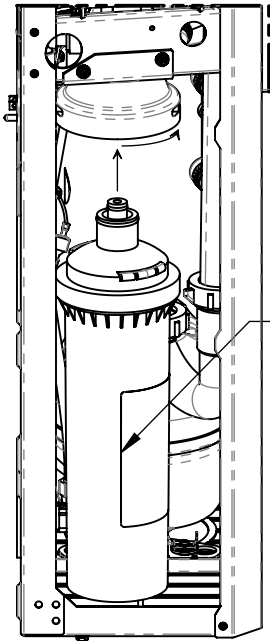

NOTE THE LEFT EDGE OF THE LABEL FACING OUT THE SIDE DURING INSERTION OF FILTER INTO FILTER HEAD

FILTER REPLACEMENT

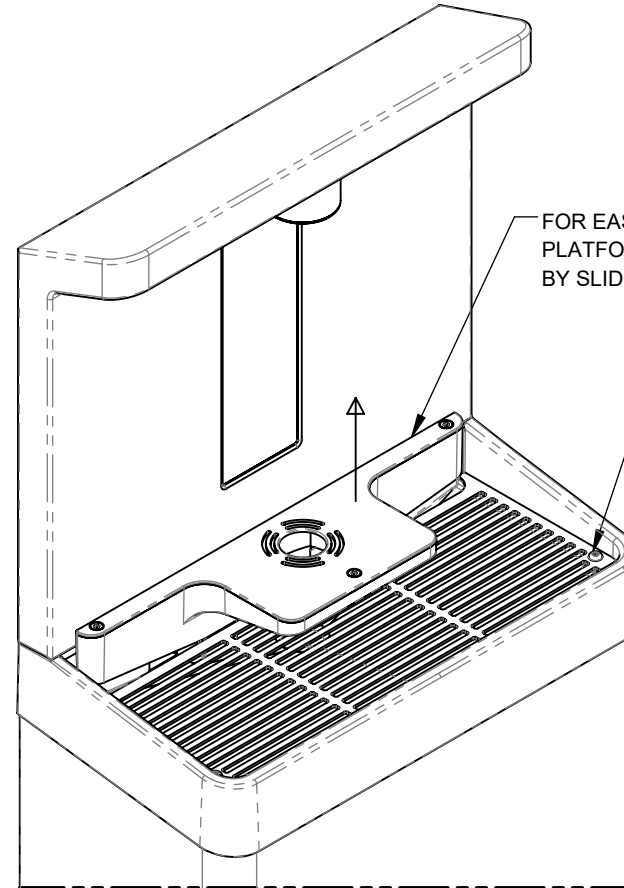

FOR EASIER CLEANING, PLATFORM CAN BE RAISED 3/4" BY SLIDING UP.

2X SCREWS CAN BE REMOVED TO ALLOW REMOVAL OF GRATE.

CLEANING DRAIN BASIN AREA

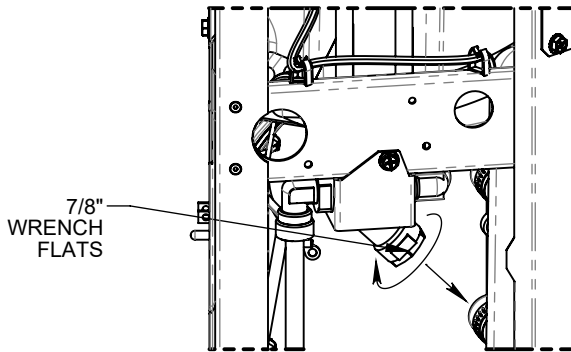

7/8" WRENCH FLATS

Y-STRAINER CLEANING



1455 KLEPPE LANE
SPARKS, NEVADA 89431
(775) 359-4712 FAX (775) 359-7424
E-MAIL: HAWS@HAWS.CO.COM
WEBSITE: WWW.HAWS.CO.COM

| | | | | |
|-----------------|-------------------|---------------|---|-----------------------------|
| ECN: 5647 | REV. ECN: 5656 | BY: DHP | MODEL(S) 12XX ELECTRIC WATER COOLERS | PART NUMBER 0510001159.D |
| DRAWN: JL | DATE: 07/25/18 | CHKD: DHP | | REVISION 1 |
| APPROVED: JL | DATE: 02/11/21 | SCALE: 1:8 | DRAWING TYPE: INSTALLATION | SIZE: A |
| | | | | SHEET 5 OF 5 |